

# ePRO

## BATTERY CHARGER

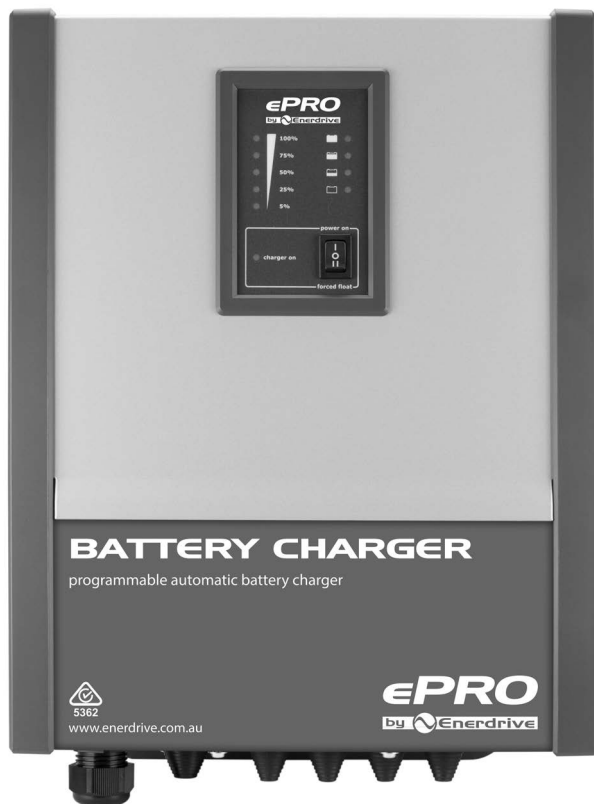

## Owner's Manual

ePRO Battery Charger 12V / 90Amp

ePRO Battery Charger 24V / 50Amp

ePRO Battery Charger 24V / 80Amp



**Enerdrive**  
DRIVING YOUR ENERGY NEEDS

---

## TABLE OF CONTENTS

1. INTRODUCTION .....	5
2. INSTALLATION .....	9
2.1 Unpacking .....	9
2.2 Mounting .....	9
2.3 Accessing the connection compartment .....	10
2.4 Wiring details .....	11
2.4.1 Control board connections and settings .....	13
2.4.2 Bottom side connections .....	14
2.5 Parallel operation .....	15
3. CONFIGURING THE BATTERY CHARGER .....	16
3.1 Selecting the correct charge program .....	16
3.2 Charge programs explained .....	18
4. GENERAL OPERATION .....	20
4.1 ePRO Battery Charger display and control overview .....	20
4.2 Charging batteries .....	21
4.3 Equalizing a flooded battery .....	22
5. TROUBLESHOOTING GUIDELINE .....	24
6. TECHNICAL SPECIFICATIONS .....	27
7. WARRANTY .....	28

---

## PLEASE KEEP THIS MANUAL FOR FUTURE REFERENCE

For safe and optimum performance, the Enerdrive ePRO Battery Charger must be used properly. Carefully read and follow all instructions and guidelines in this manual and give special attention to the CAUTION and WARNING statements.

### Disclaimer

While every precaution has been taken to ensure the accuracy of the contents of this guide, Enerdrive assumes no responsibility for errors or omissions. Note as well that specifications and product functionality may change without notice.

### Important

Please be sure to read and save the entire manual before using your Enerdrive ePRO Battery Charger. Misuse may result in damage to the unit and/or cause harm or serious injury. Read manual in its entirety before using the unit and save manual for future reference.

### Product Numbers - ePRO Battery Charger Series

EPBC-1290	ePRO Battery Charger 12V / 90Amp
EPBC-2450	ePRO Battery Charger 24V / 50Amp
EPBC-2480	ePRO Battery Charger 24V / 80Amp

ePRO Battery Charger Owners Manual Rev. 1.0. This Manual is applicable to all units with serial number prefix EPBC.

### Service Contact Information

ENERDRIVE PTY LTD

Unit 11, 1029 Manly Road Tingalpa, Queensland, Australia 4173

Ph: 1300 851 535 / Fax: 07 3390 6911

Email: [sales@enerdrive.com.au](mailto:sales@enerdrive.com.au) | Web: [www.enerdrive.com.au](http://www.enerdrive.com.au)

## **NOTICE OF COPYRIGHT**

Enerdrive ePRO Battery Charger owner's manual © 2016 Enerdrive . All rights reserved. No part of this document may be reproduced in any form or disclosed to third parties without the express written permission of Enerdrive Pty Ltd, Unit 11, 1029 Manly Road Tingalpa, Queensland, Australia 4173. Enerdrive reserves the right to revise this document and to periodically make changes to the content hereof without obligation or organization of such revisions or changes, unless required to do so by prior arrangement.

### **EXCLUSIONS FOR DOCUMENTATION AND PRODUCT USAGE**

1. Unless specifically agreed to in writing, Enerdrive Pty Ltd : makes no warranty as to the accuracy, sufficiency or suitability of any technical or other information provided in its manuals or other documentation
2. Assumes no responsibility or liability for losses, damages, costs or expenses, whether special, direct, indirect, consequential or incidental, which might arise out of the use of such information. The use of any such information will be entirely at the user's risk
3. Makes no warranty, either expressed or implied, including but not limited to any implied warranties of merchantability or fitness for a particular purpose, regarding these Enerdrive products and makes such Enerdrive products available solely on an "as is" basis.
4. Shall in no event be liable to anyone for special, collateral, incidental, or consequential damages in connection with or arising out of purchase or use of these Enerdrive products. The sole and exclusive liability to Enerdrive, regardless of the form of action, shall not exceed the purchase price of the Enerdrive products described here in.

## 1. INTRODUCTION

Thank you for purchasing the Enerdrive ePRO Battery Charger. With our state of the art, easy to use design, this product will offer you reliable service for providing a multistage, multi-bank battery charger to charge the different types of batteries you have installed in either your home, boat, caravan or commercial vehicle. This manual will explain how to use this unit safely and effectively. Please read and follow these instructions and precautions carefully.

### IMPORTANT SAFETY INFORMATION

This section contains important safety information for the Enerdrive ePRO Battery Charger. Each time, before using the Enerdrive ePRO Battery Charger, READ ALL instructions and cautionary markings on or provided with the battery charger, and all appropriate sections of this guide. The Enerdrive ePRO Battery Charger contains no user serviceable parts. Opening up the charger will void product warranty. See Warranty section for how to handle product issues.



### WARNING

#### **FIRE AND/OR CHEMICAL BURN HAZARD**

Do not cover or obstruct any air vent openings and/or install in a zero-clearance compartment.



### WARNING

#### **SHOCK HAZARD. KEEP AWAY FROM CHILDREN!**

Avoid moisture ingress. Never expose the unit to snow, water, etc.



## WARNING

### **FAILURE TO FOLLOW THESE INSTRUCTIONS CAN RESULT IN DEATH OR SERIOUS INJURY**

When working with electrical equipment or lead acid batteries, have someone nearby in case of an emergency.

Study and follow all the battery manufacturer's specific precautions when installing, using and servicing the battery connected to the charger.

Wear eye protection and gloves.

Avoid touching your eyes while using this unit.

Keep fresh water and soap on hand in the event battery acid comes in contact with eyes. If this occurs, cleanse right away with soap and water for a minimum of 15 minutes and seek medical attention.

Batteries produce explosive gases. DO NOT smoke or have an open spark or fire near the system.

Never attempt to re-charge a damaged, frozen or non-rechargeable battery.

Keep unit away from moist or damp areas.

Avoid dropping any metal tool or object on the battery. Doing so could create a spark or short circuit which goes through the battery or another electrical tool that may create an explosion.

Battery charger must be plugged in to an earthed and Australian Standards compliant mains supply. If the units power cable is damaged, replace the cable immediately.



## **WARNING: EXPLOSION HAZARD!**

DO NOT use the Enerdrive ePRO Battery Charger in the vicinity of flammable fumes or gases (such as gas bottles or large engines).

AVOID covering the ventilation openings. Always operate unit in an open and well ventilated area.

Prolonged contact to high heat or freezing temperatures will decrease the working life of the unit.



## **LIMITATIONS OF USE**

Do not use in connection with life support systems or other medical equipment or devices.

Charger is not to be used by persons with reduced physical or mental capabilities or lack of knowledge and experience. Not to be operated or used by children.

## 2. INSTALLATION

### 2.1 Unpacking

The charger package should contain the following items :

Battery charger

Wall bracket

Battery temperature sensor (3m)

Owner's manual

Safety flyer

Charger warning stickers

2 x M8 crimp terminals

7 x mounting screws

### 2.2 Mounting

Please see the image below for the mounting method.

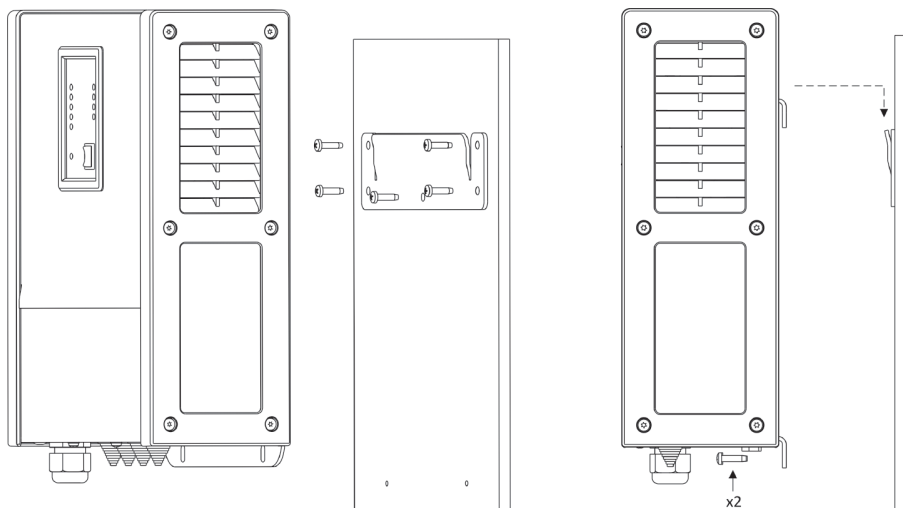



The image below shows the mutual distances of the drilling holes.

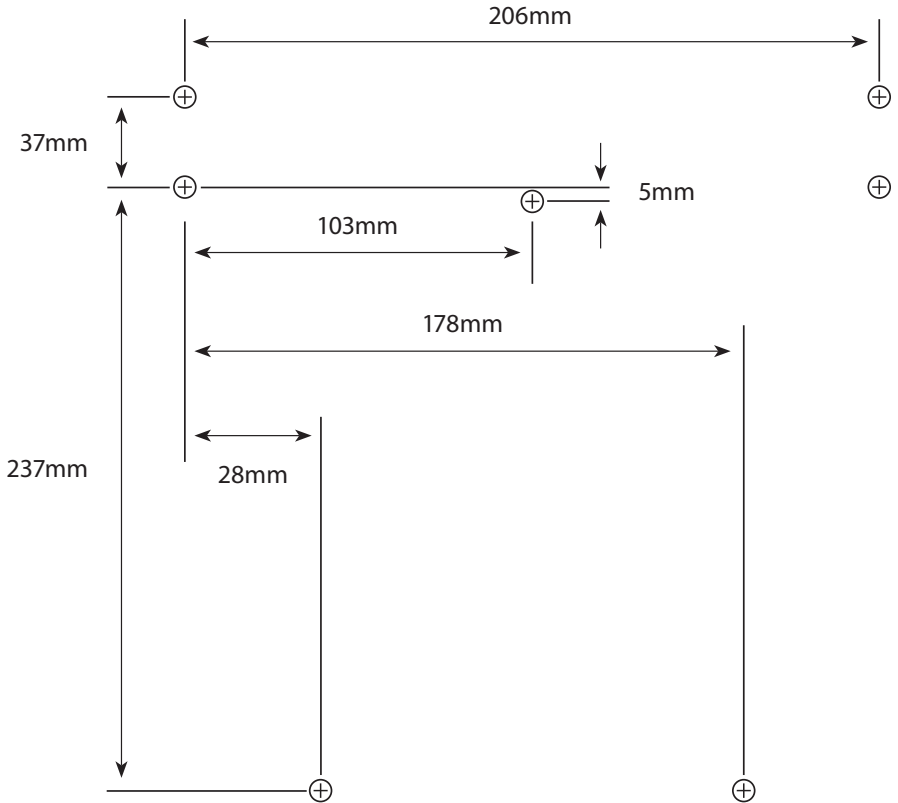

## CAUTION

Keep a clear space of at least 10 cm around this product for cooling purposes! Always mount this product in an upright position. Floor mounting is allowed as well, provided that all 7 screws are used to secure the enclosure.



## WARNING

To reduce the risk of explosion, never use this product in locations where there is danger of gas- or dust explosions or where ignition protected equipment is mandatory. Never install the charger directly on top of the battery or vice-versa.

### 2.3 Accessing the connection compartment

To access the connection compartment, remove the two screws indicated on the left and slide the red connection compartment cover downwards.



## WARNING

Never operate this product without having the cover re-installed!

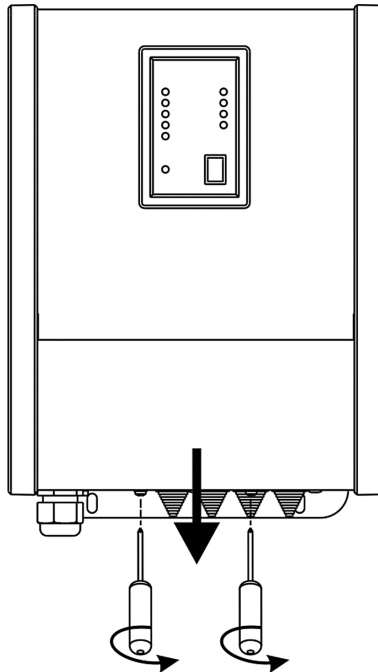

## 2.4 Wiring details

Please see the image below for the wiring details.

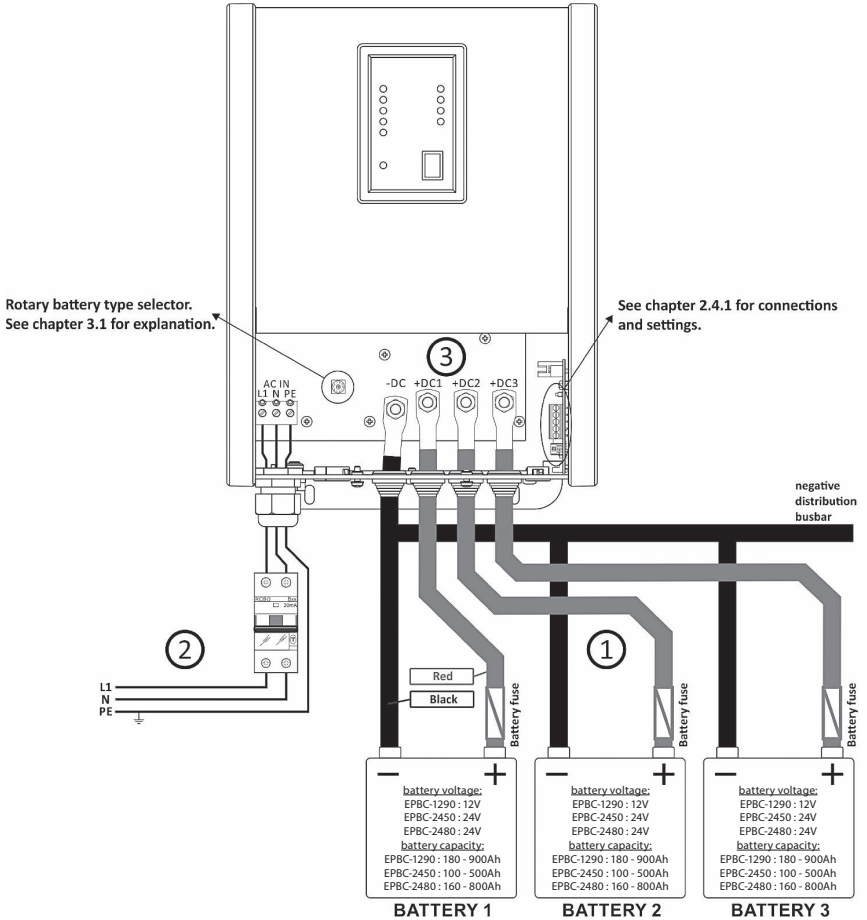

- 1 Please consult the following table to determine the correct battery cable and fuse size for each model. Using a smaller cable size or a longer cable will cause additional losses and may result in improperly charged batteries. Fire and burning hazards are present if the battery cables are insufficiently sized for the expected current. Battery cable lengths longer than 6 meters, are not recommended.

Model	Cable size (*length ≤ 3 m)	Cable size (*length = 3 to 6m)	Battery fuse (quick type)
EPBC-1290	35mm <sup>2</sup> (AWG2)	50mm <sup>2</sup> (AWG0)	100-120Amp
EPBC-2450	25mm <sup>2</sup> (AWG3)	35mm <sup>2</sup> (AWG2)	60-80Amp
EPBC-2480	35mm <sup>2</sup> (AWG2)	50mm <sup>2</sup> (AWG0)	100-120Amp

\* Note: Cable size length is a total of both the Positive and Negative cable run.

- ② The AC input must be protected by an earth leakage circuit breaker with over-current protection (RCBO), that can withstand the maximum nominal current consumption from the charger without tripping. All AC wiring must be sized accordingly. Please consult the following table to determine the correct AC wiring and RCBO sizes:

Model	AC wiring size / RCBO size (220-240VAC)	AC wiring size / RCBO size (100-120VAC)
EPBC-1290	1.5mm <sup>2</sup> (AWG15) / 8A (30mA)	2.5mm <sup>2</sup> (AWG13) / 16A (30mA)
EPBC-2450	1.5mm <sup>2</sup> (AWG15) / 10A (30mA)	4mm <sup>2</sup> (AWG11) / 20A (30mA)
EPBC-2480	2.5mm <sup>2</sup> (AWG13) / 16A (30mA)	-

Please make sure that the information in this table is in accordance to all locally applicable electrical regulations.

- ③ Up to 3 battery banks can be connected to the charger. Each output can supply the full rated charging current. The total charging current of all 3 outputs combined, will never exceed the maximum rated charging current. All 3 outputs are isolated from each other by highly efficient active rectifiers.



## WARNING

The schematic (left) shows a typical standalone installation. No guarantees are given on the compliance of any local electrical regulations. Please make sure that the complete installation is made in accordance to all locally applicable electrical regulations.



## WARNING

This Class I product must be earthed! Always connect the PE wire or chassis ground screw at the bottom of the enclosure to your central ground (vehicle chassis, grounding system of your boat etc.)



## CAUTION

Always connect the negative (-) cable directly on the negative terminal of the battery, or on the “loadside” of a current shunt. Always keep positive and negative cables close to each other to minimize electromagnetic fields. Double check for correct polarity, before connecting the battery cables to the battery! Wrong polarity may damage the charger.



## CAUTION

Please feed all connection compartment wiring through the rubber grommets and plastic gland.

### 2.4.1 Control board connections and settings

The following image shows the control board connections and switch options.

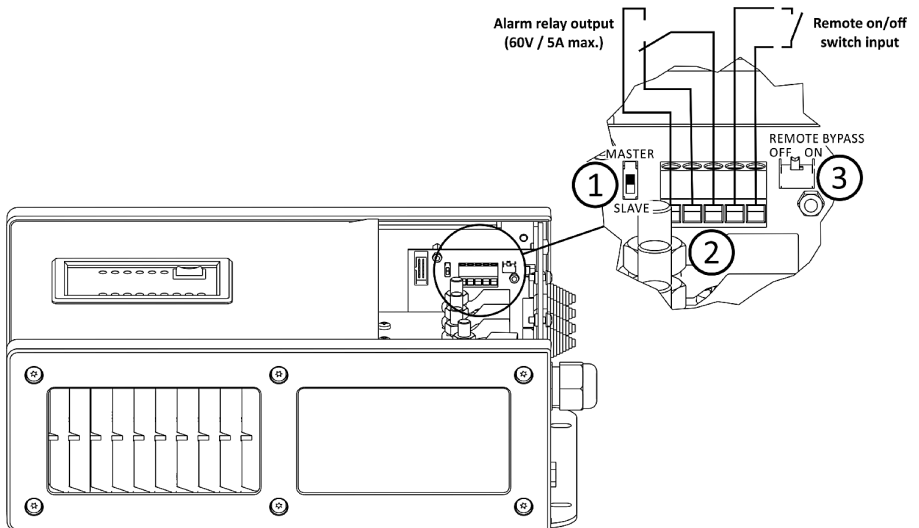

- 1 Master/slave switch position. This switch must be set to 'MASTER' when a single charger is installed. The 'SLAVE' setting is only relevant for parallel charger systems.

- ② 5 pole screw terminal block. The first three positions are connected to the 'normally open', 'normally closed' and 'common' contacts of the internal alarm relay. This relay will be activated when the charger shuts down into an error mode. When the error condition has been cleared, this relay will de-activate again. Please make sure not to exceed the maximum relay contact rating of 60V and 5A to avoid damaging the relay or PCB. On the 4th and 5th position of the screw terminal, an external switch can be connected to remotely turn the charger on and off. This switch can be located up to 50 meters away from the charger. It is advised to use a wire size of 1mm<sup>2</sup> (AWG17) for the remote switch connection. For the remote switch, any single pole switch can be used. Only a low power signal must be switched on this line.
- ③ Remote bypass switch position. When a remote switch is connected to the 5 pole screw terminal block, the remote bypass switch must be set to OFF. When no remote switch is used, the remote bypass switch must be set to ON.

### 2.4.2 Bottom side connections

Please see the next image for the bottom side connections.

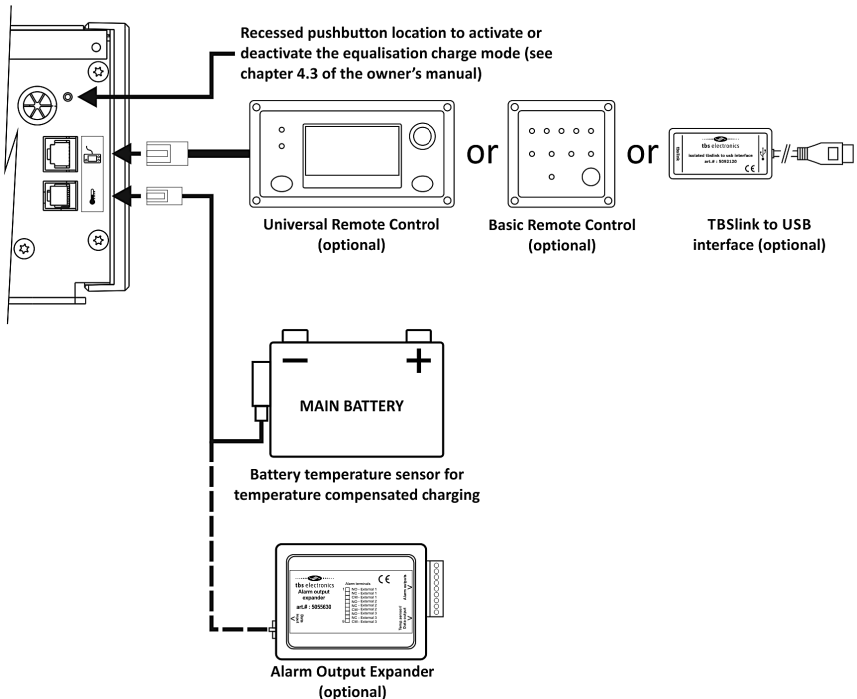

## **2.5 Parallel operation**

Up to 6 battery chargers of the same model can be connected in parallel, in order to reach very high charge current levels. This manual will not show any connection or operation details for paralleled charger systems. Such details are explained in the documentation that is included with the optional “ePRO Battery Charger XL Parallel Kit (Part.# EPBC-PK)”.

### 3. CONFIGURING THE BATTERY CHARGER

#### 3.1 Selecting the correct charge program

The image in chapter 2.4 showed the location of the rotary selector, which is used to select the desired charge program. The charge program selection depends on the type of battery that needs to be charged. Each battery type has its own typical bulk and float charge voltages. When your battery type or optimal charging voltages are still not available in the standard list, you can select rotary position '0' and setup the battery charger using the Dashboard for Windows software. This software is included in the optional ePRO Link to USB Communication Kit (Part.# 5092120), which also contains an isolated interface box required to connect the ePRO Battery Charger to a PC. Using Dashboard, all available parameters can be edited, and it is also possible to edit or create your own battery charge programs.



### CAUTION

Invalid battery type settings can cause serious damage to your batteries and/or connected battery loads. Always consult your battery's documentation for the correct charge voltage settings.

In the following table, all settings are explained.

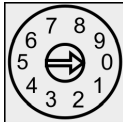
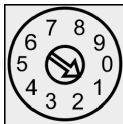
Selector position	Battery type	Voltage (12V/24V) and maximum timer settings
 Position 0	Custom (empty from factory)	The voltage settings for this position are empty. Connect the charger to a PC running Dashboard and create a custom charge program to save on this position. If not, the charger will return a battery error when the selector is set to '0'.
 Position 1	Flooded (factory default setting)	Absorption voltage = 14.40V or 28.80V Float voltage = 13.50V or 27.00V Equalize voltage = 15.80V or 31.60V Max. bulk time = 8hrs Max. absorption time = 4hrs

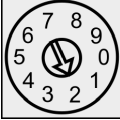
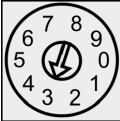
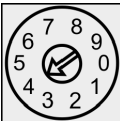
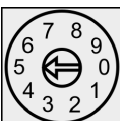
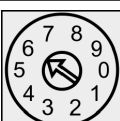
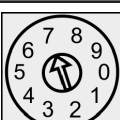
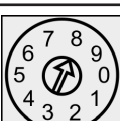

 Position 2	<p>GEL</p>	<p>Absorption voltage = 14.20V or 28.40V            Float voltage = 13.50V or 27.00V            Equalize voltage = equalize not available            Max. bulk time = 8hrs            Max. absorption time = 4hrs</p>
 Position 3	<p>AGM (also for Optima SpiralCell)</p>	<p>Absorption voltage = 14.70V or 29.40V            Float voltage = 13.65V or 27.30V            Equalize voltage = 15.50V or 31.00V            Max. bulk time = 8hrs            Max. absorption time = 4hrs</p>
 Position 4	<p>Lead Calcium</p>	<p>Absorption voltage = 14.80V or 29.60V            Float voltage = 13.50V or 27.00V            Equalize voltage = 15.80V or 31.60V            Max. bulk time = 16hrs            Max. absorption time = 8hrs</p>
 Position 5	<p>LiFePO4</p>	<p>Absorption voltage = 14.40V or 28.80V            Float voltage = 13.80V or 27.60V            Equalize voltage = equalize not available            Max. bulk time = 12hrs            Max. absorption time = 12hrs</p>
 Position 6	<p>Empty</p>	<p>Reserved for future use. If selected anyway, the charger will return a battery error.</p>
 Position 7	<p>Empty</p>	<p>Reserved for future use. If selected anyway, the charger will return a battery error.</p>
 Position 8	<p>Empty</p>	<p>Reserved for future use. If selected anyway, the charger will return a battery error.</p>

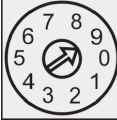
 <p>Position 9</p>	<p>Empty</p>	<p>Reserved for future use. If selected anyway, the charger will return a battery error.</p>
-----------------------------------------------------------------------------------------------------	--------------	----------------------------------------------------------------------------------------------

This manual will only describe the rotary selector settings. Configuration by Dashboard will be explained in the Dashboard manual that comes with the ePRO Link to USB Communication Kit.

### 3.2 Charge programs explained

Most standard selectable charge programs, perform a four stage IUoUoP charging process comprising of a "Bulk", an "Absorption", a "Float" and a "Pulse" stage. The image below visualizes the four stage charging process :

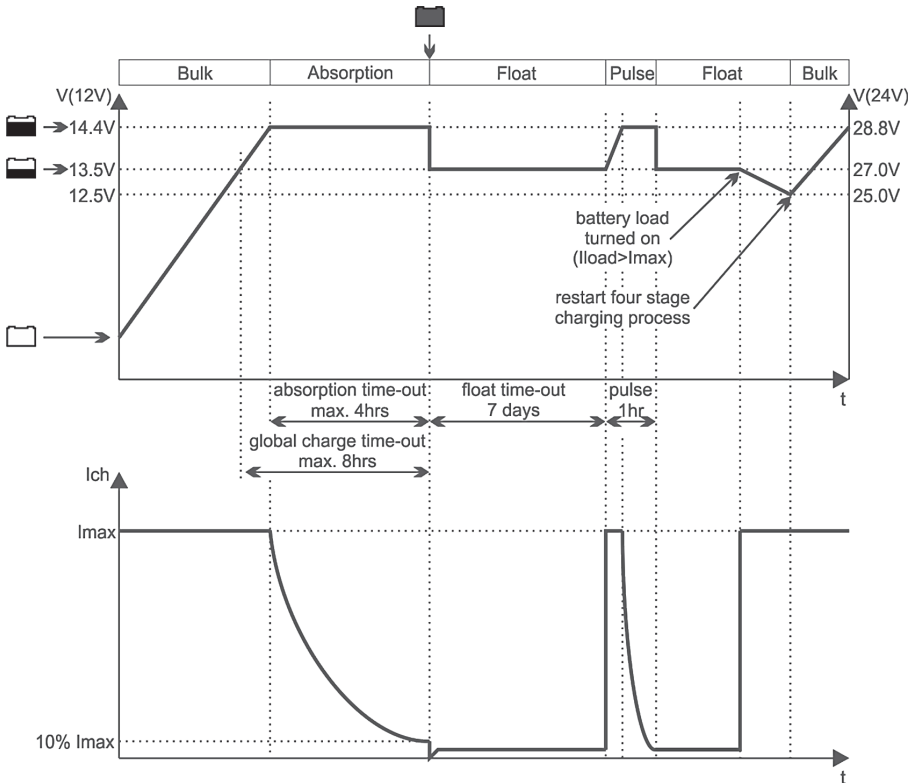

In the Bulk stage, the charger delivers full output current and typically returns approximately 80% of charge back into the battery once the absorption voltage is reached. During this stage, indicators 3d and 3c (see frontpanel image in chapter 4.1) will be lit depending on the Bulk charge progress.

When the absorption voltage has been reached, the Absorption stage will be entered and indicator 3b will be lit. This stage will return the final 20% of charge to the battery. The output voltage is kept at a constant level and the charge current decreases as a function of the battery's state of charge. When the charge current has dropped below a certain value or when the maximum absorption timer has been expired, the Float stage will be entered.

Indicator 3a will be lit and an acoustical message will sound, indicating that the battery is full. In this stage the battery voltage will be held constant at a safe level for the battery. It will maintain the battery in optimal condition for as long as the battery remains connected to the activated charger. Connected battery loads will be directly powered by the charger up to the charger's maximum output current level. When even more current is drawn, the battery must supply this which results in a declining battery voltage. At a certain battery voltage level, the charger jumps back to the Bulk stage and will finalize a complete four stage charging process again, once the battery load consumption has dropped below the charger's maximum output current level.

The fourth stage called "Pulse", will perform a short refresh charge of approximately 1 hour each 7 days while the charger operates in the Float stage. This will keep the battery in optimal condition while prolonging its lifetime. The battery can remain connected to the activated charger continuously, without risk of overcharging.

When the battery temperature sensor is installed, the charger automatically compensates the charge voltages against battery temperature. This means that the charge voltages are slightly increased at lower temperatures and decreased at higher temperatures (-30mV/°C at 12V chargers and -60mV/°C at 24V chargers). This way, overcharging is prevented which prolongs your battery's lifetime. A connected battery temperature sensor also enables the battery temperature protection, which stops the charging process when the battery's temperature is below -20°C or above +50°C.

## 4. GENERAL OPERATION

### 4.1 ePRO Battery Charger display and control overview

See the next image for an overview of all LED indicators on the ePRO Battery Charger frontpanel, as well as the location of the main switch.

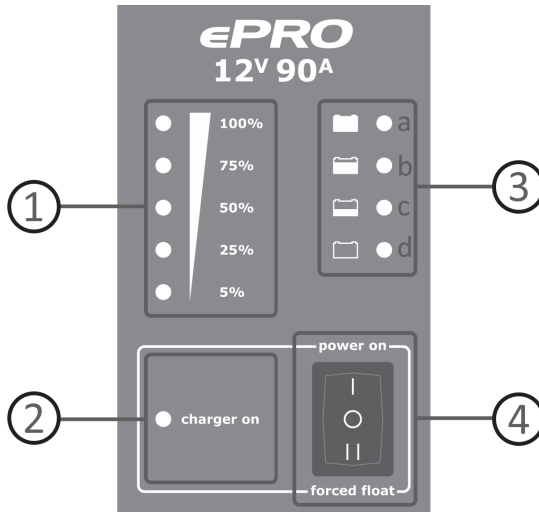

The frontpanel can be divided into four sections :

- ① Output current bar. Indicates the percentage of total delivered charging current.
- ② Mode indicator. Indicates the operating mode of the battery charger

Indicator mode	Description
Continuous green	Power on, normal mode
Flashing red (1 flash per sec.)	<p>Battery error</p> <p><i>A battery error can appear for several reasons. These are : battery voltage is too low (too deeply discharged) or too high and battery temperature is too low or too high (only available when battery temperature sensor is connected). The charger will not restart automatically in battery error mode, except when this error was generated due to a too low battery voltage or a too low battery temperature.</i></p>

Flashing red (2 flashes per sec.)	High/low AC input voltage
Flashing red (3 flashes per sec.)	High charger temperature The charger automatically restarts when the temperature is below an acceptable level.
Flashing red (4 flashes per sec.)	Charger error (return for service)

③ Charge status bar. Gives a rough indication of the charging progress, see below :

LED 3a : 100% full (ready)

LED 3b : 80% full

LED 3c : 50% full

LED 3d:empty

④ Power on, off, charger only switch.

Switch position	Description
"0"	Charger off <i>When the switch is in position "0", it does not interrupt any internal AC or DC sources. This means that there are still lethal voltages present inside the charger! In position "0", the charger will still consume a small amount of AC current.</i>
"I"	Charger on in automatic charging mode
"II"	Charger on in forced float mode <i>In this mode, the output voltage of the charger is set constantly to the float voltage (value is depending on selected battery type) while being able to deliver full rated output current. Since no automatic charging programs are activated in this mode, it can be used for constant voltage charging or operating the charger as a battery buffered power supply.</i>

## 4.2 Charging batteries



### CAUTION

Before you start to charge batteries, read all enclosed safety instructions and warnings while following all safety precautions about working with batteries.

The list below globally describes the steps to follow for charging batteries :

1. Push the charger switch in the "O" (Off) position and disconnect the AC supply to the charger
2. If possible disconnect or switch off all loads from the battery
3. Connect the battery to the charger
4. Switch on the AC supply and activate the charger by pushing the charger switch in the "I" (power on) position. After a two tone beep, the charger will start the charging proces.
5. After charging is completed, push the charger switch in position "O" and switch off the AC supply again, before disconnecting the battery. Or, keep all connections and the charger switch position untouched and just re-connect all battery loads.

### **4.3 Equalizing a flooded battery**

If you are using a lead acid battery, an occasional equalization charge cycle may be recommended by the manufacturer. This might also be true when the battery has been very deeply discharged or often charged inadequately. During equalization, the battery will be charged up to approx. 15.5V (or 31V for 24V models) at a reduced output current level. Before starting an equalization charge cycle, the following caution statements must be read carefully :



## CAUTION

Equalization should only be performed on a lead acid battery type that supports this process. Therefore the ePRO Battery Charger only allows equalization when the battery type rotary selector is set to Flooded, AGM or Lead Calcium. Other battery types like GEL or Lithium will be damaged by this process. Please be aware that not all AGM and Lead Calcium battery manufacturers allow an equalization process. Always follow the battery manufacturer's instructions when equalizing batteries.

During equalization, the battery generates explosive gasses. Follow all the battery safety precautions enclosed with your ePRO Battery Charger. Ventilate the area around the battery sufficiently and ensure that there are no sources of flames or sparks in the vicinity.

Disconnect all loads connected to the battery during equalization. The voltage applied to the battery during this process may be above safe levels for some loads.

The ePRO Battery Charger cannot automatically determine when to stop the equalization of a battery. The user must monitor the battery's specific gravity throughout this process to determine the end of the equalization cycle. The internal 1 hours time-out timer of your charger is only intended as a safety feature, but may not be sufficiently short to prevent battery damage. Therefore, equalizing a battery is always a process that must continuously be supervised by the user.

As explained earlier, the ePRO Battery Charger will only allow equalization when the battery type rotary selector is set to a battery type that may allow an equalization cycle. Besides this, the charger also needs to have a full charge cycle completed and must operate in the Float stage. When these two conditions are met, the equalization charge mode can be activated by pressing the recessed pushbutton on the bottom side of the unit (see image in chapter 2.4.2) for 3 seconds, until all charge status indicators start flashing.

The ePRO Battery Charger battery charger will allow a maximum equalization time of 1 hour before it automatically jumps back to the Float stage. If the specific gravity of each cell does not match the battery manufacturer's specifications yet, you can initiate a new 1 hour equalization cycle by pressing the pushbutton for 3 seconds again. Always keep on checking the specific gravity of each cell repeatedly during the equalization process. When these values are correct, you can manually exit the equalization process by pressing the recessed pushbutton once. The battery charger will then return to the Float stage.

## 5. TROUBLESHOOTING GUIDELINE

Please see the table below if you experience any problems with the ePRO Battery Charger battery charger and/or the installation.

Problem	Possible cause	Remedy
ePRO Battery Charger is not working at all.	Main switch in Off (0) position.	Push the power switch in the 'I' or 'II' position.
	AC input voltage is out of range or not available.	Make sure the AC input voltage is available and within the operating range of the charger.
	Remote switch or ePRO Remote Control has deactivated the charger.	Activate the charger remotely or check if the remote bypass switch is set correctly.
	Poor contact between the charger battery wires and the battery terminals.	Clean battery terminals or charger wire contacts. Tighten battery terminal screws.
	Blown DC fuse.	Check battery fuse or internal charger output fuse (located on charger PCB).
	Very poor battery condition.	Replace battery.
The battery is not being charged up to it's maximum capacity.	Incorrect absorption charge voltage setting.	Check the battery type selector for correct settings. Or adjust the absorption voltage using Dashboard.
	Incorrect charge current setting.	Adjust the charge current using the Universal Remote Control or Dashboard. Typically, the charge current should be set to 10%-20% of the total battery capacity
	Too much voltage loss in battery cables and/or connections.	Make sure that the battery cables have a large enough diameter. Check if all DC connections are solidly made.
	Additional battery loads are consuming too much current during charging.	Turn-off or disconnect all battery loads.



Charge current is too low.	High ambient temperature.	Try to lower the ambient temperature around the charger
	Charger is operating in the absorption charging stage.	Do nothing. The battery is almost fully charged and consumes less current by itself.
Charge voltage is too low.	The charge voltage is being compensated by the battery temperature sensor to protect the battery.	Do nothing or try to cool down the ambient temperature around the battery.
	Wrong battery type selected, or custom charge program needs to be re-adjusted.	Select the correct battery type or adjust the custom charge program using Dashboard.
	DC cables too thin.	Install larger DC cables. See the DC cable size table in chapter 2.4.
	Battery load current is higher than the charger's output current.	Reduce or remove the battery load.
LED 'charger on' is blinking red once per second (battery error).	Battery voltage is too low. (must be > 6V @12V and >12V @24V systems)	Battery is damaged, replace it. Or battery has been discharged too extremely.
	Battery voltage is too high. (> 15% of set charge voltage).	Check the DC system for an external source that pushes the battery voltage too high.
	Battery temperature is too high or too low. (only available when temperature sensor is installed)	Make sure that the battery is located in a better environment to charge batteries.
LED 'charger on' is blinking red twice per second (AC error).	AC input voltage is too high or too low.	Please make sure that the AC input voltage is within the operating range of the charger.

LED 'charger on' is blinking red three times per second (high charger temperature error).	Airflow around the charger is obstructed.	Make sure there is at least 10 centimeters of clearance around the charger. Remove any items placed on or over the charger. Keep the charger away from direct sunlight or heat producing equipment.
	Too high ambient temperature.	Move the charger to a cooler environment or provide additional cooling by an external fan.
LED 'charger on' is blinking red four times per second (charger error).	An internal error is detected.	Please return the charger to your nearest dealer for service.

If none of the above remedies will help solving the problem you encounter, it's best to contact your local Enerdrive distributor for further help and/or possible repair of your ePRO Battery Charger. Do not disassemble the charger yourselves, there are dangerously high voltages present inside and it will also void your warranty.

## TECHNICAL SPECIFICATIONS

Parameter	EPBC-1290	EPBC-2450	EPBC-2480
AC input voltage	100-260Vac / 47-63Hz / PF > 0.9		180-260Vac
Full load power consumption	1550VA	1700VA	2750VA
AC input current (115V/230V)	13.5A / 6.8A	15A / 7.5A	- / 12A
Total DC output current(1) (4)	90A	50A	80A
Nominal DC output voltage(1)	12Vdc	24Vdc	
Number of full current outputs	3 (internally isolated)		
Charge characteristic(2)	IUoUoP, intelligent 4-stage, temp. compensated		
Standard absorption voltage(2)	14.4Vdc	28.8Vdc	
Standard float voltage(2)	13.5Vdc	27.0Vdc	
Standard equalize voltage(2)	15.8Vdc	31.6Vdc	
Supported battery types(2)	Flooded / Gel / AGM / LiFePO4 / Custom		
Recommended battery capacity(3)	180-900Ah	100-500Ah	160-800Ah
DC current draw (charger off)	< 0.1mA		
Operating temp. Range	-10°C...+55°C (humidity max. 90% non condensing)		
Storage temp. Range	-20°C...+70°C (humidity max. 90% non condensing)		
Cooling	Variable speed fan		
ePRO Link enabled	Yes		
Protections	Low AC input voltage, output short circuit, high temperature, battery overcharging and reverse polarity (fuse)		
Indications	Power on, output current, state of charge, error		
DC output connections	4x M8 bolts		
AC input connections	Screw terminals		
Enclosure body size (HxWxD)	370 x 271 x 132mm		
Total weight	6.2kg		
Protection class	IP21 (mounted in upright position)		
Standards	CE marked. EMC : EN55016-2-1(A1), EN55016-2- 3(A1), EN 61000-4-2(3/4/5/6). Safety : EN60335-1, EN60335-2-29 Complies with AS/NZS 60335.2.29 Including Australian deviations.		

Note : the given specifications are subject to change without notice.



- 1) Maximum output current tolerance is +/-5%. Maximum set point voltage deviations are +/-1%. All set point voltages are temperature compensated when the battery temperature sensor is connected.
- 2) Value is programmable.
- 3) Always consult battery manufacturers specifications for maximum allowable charge current.
- 4) At higher ambient temperatures (>40°C), maximum output current may be reduced automatically.

## **WARRANTY**

### **Two Year Limited Warranty**

Our goods come with guarantees that cannot be excluded under the Australian Consumer Law. You are entitled to a replacement or refund for a major failure and for compensation for any other reasonably foreseeable loss or damage. You are also entitled to have the goods repaired or replaced if the goods fail to be of acceptable quality and the failure does not amount to a major failure.

The limited warranty program is the only one that applies to this unit, and it sets forth all the responsibilities of Enerdrive. There is no other warranty, other than those described herein. Any implied warranty of merchantability of fitness for a particular purpose on this unit is limited in duration to the duration of this warranty.

This unit is warranted, to the original purchaser only, to be free of defects in materials and workmanship for two years from the date of purchase without additional charge. The warranty does not extend to subsequent purchasers or users other than OEM applications.

This unit is not intended for commercial use. This warranty does not apply to damage to units from misuse or incorrect installation/connection. Misuse includes wiring or connecting to improper polarity power sources.

Damage from high AC voltage surges are not covered under warranty. Such damage can occur from unregulated portable generators or lightning strike.

### **Return and/or Repair Policy**

If you are experiencing any problems with your unit, please contact our customer service department at [support@enerdrive.com.au](mailto:support@enerdrive.com.au) or Phone 1300 851 535 before returning product to retail store. After speaking to a customer service representative, if products are deemed non-working or malfunctioning, the product may be returned to the purchasing store within 30 days of original purchase. Any defective unit that is returned to Enerdrive within 30 days of the date of purchase will be replaced free of charge.

If such a unit is returned more than 30 days but less than two years from the purchase date,

Enerdrive will repair the unit or, at its option, replace it, free of charge. If the unit is repaired, new or reconditioned replacement parts may be used, at manufacturer's option. A unit may be replaced with a new or reconditioned unit of the same or comparable design. The repaired or replaced unit will then be warranted under these terms for the remainder of the warranty period. The customer is responsible for the shipping charges on all returned items back to Enerdrive.

### **Limitations**

This warranty does not cover accessories, such as adapters and batteries, damage or defects result from normal wear and tear (including chips, scratches, abrasions, discolouration or fading due to usage or exposure to sunlight), accidents, damage during shipping to our service facility, alterations, unauthorized use or repair, neglect, misuse, abuse, failure to follow instructions for care and maintenance, fire and flood.

If your problem is not covered by this warranty, contact our Support Team at [support@enerdrive.com.au](mailto:support@enerdrive.com.au) or phone 1300 851 535 for general information if applicable.



---

Notes:

-----  
-----  
-----  
-----  
-----  
-----  
-----  
-----  
-----  
-----  
-----  
-----  
-----  
-----  
-----  
-----  
-----  
-----  
-----  
-----  
-----  
-----  
-----



**ENERDRIVE PTY LTD**

Unit 11, 1029 Manly Road Tingalpa, Queensland, Australia 4173

Ph: 1300 851 535 / Fax: 07 3390 6911

Email: [support@enerdrive.com.au](mailto:support@enerdrive.com.au)

Web: [www.enerdrive.com.au](http://www.enerdrive.com.au)